



Agilent AN 1305-2

Insulation Resistance Measurement of Plate-Type Materials

Application Note



High Resistance Measurement Configuration (Agilent 4339B High Resistance Meter and 16008B Resistivity Cell)

Introduction

To improve or verify the quality of insulation materials such as the plate-type polymer sheets, it's important to accurately measure the electrical characteristics of the material, especially insulation resistance. This application note describes how the Agilent Technologies 4339B High-Resistance Meter helps make precise insulation resistance measurements easy.

Problems with Traditional Measurement Equipment

It's difficult to make reliable insulation using traditional high-resistance measuring equipment for a number of reasons:

- Insulation resistance results are obtained a specified time (e.g., 60 seconds) after the test voltage is applied. Test operators find it difficult to obtain precise timing using a clock, and timing variations cause inconsistent measurement results.

Figure 1. Volume Resistivity and Surface Resistivity

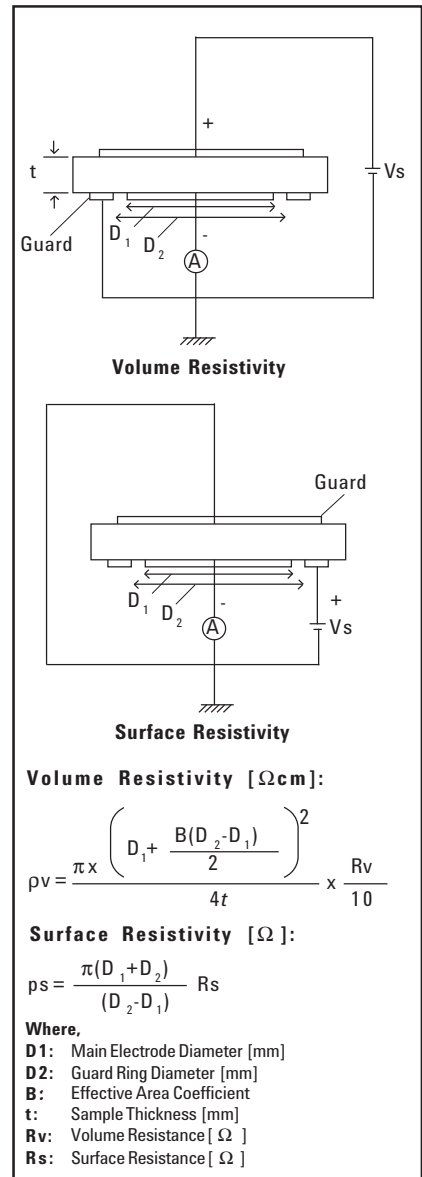

Agilent Technologies

Innovating the HP Way

- Surface or volume resistivity, an important characteristic of insulation material, isn't measured directly. Instead, you must calculate it using the data from the resistance measurement.
- Traditional measuring equipment doesn't produce stable results for high-resistance insulation material.
- Correctly sized test-fixture electrodes haven't been available.
- Parasitic errors in the test fixture degrade measurement accuracy.

The Agilent 4339B Solution

You can readily make accurate insulation resistance measurements with the 4339B high-resistance meter. Five key factors eliminate the problems encountered using traditional equipment:

1. Test sequence program—The 4339B's test sequence program automatically performs precisely timed sequential measurement steps for the charge/measure/discharge process. You get consistent measurement results because the sample of material is charged for exactly the specified time.

2. Automatic resistivity calculation—The 4339B calculates the volume resistivity and surface resistivity using the formula shown in Figure 1. You just enter the thickness value of the sample and the electrode size of the test fixture into the instrument before

Electrode Size:	26/50/76 mm²
Device Size (diameter):	50 mm to 125 mm
Device Thickness:	10 μm to 10 mm
Operating Load:	10 kgf max.
Operating Temperature:	-30°C to 100°C

Table 1. Agilent 16008B Specifications

1. 50 mm is standard. 26/76 is optional.

the measurement, then read the volume or surface resistivity directly from the 4339B's display after the measurement. It's simple and easy.

3. Reducing the effects of noise—Normally results of measurements of ultra high resistances (above $1 \times 10^{14} \Omega$) may be unstable due to the effects of external noise. The 4339B, which can measure resistance up to $1.6 \times 10^{16} \Omega$, uses the triaxial input terminal configuration to minimize noise problems. To obtain measurement stability in difficult measurements, use the available test fixture with shield cover, and apply the 4339B's Averaging function (1 through 256).

4. A quality test fixture—A test setup that combines the 4339B and the 16008B Resistivity Cell (see specifications in Table 1) allows stable measurements of surface and volume resistance/resistivity. The three kinds of electrodes available for the 16008B test fixture meet the requirements of the various standards used for insulation material evaluation (Table 2).

5. Error correction—Sources of parasitic error in the test fixture can cause major measurement error, especially for ultra high resistance measurements. Leakage currents through stray paths in the fixture can be quite large relative to the measurement current.

Standard	Material	Electrode Diameter (mm)
JIS:		
K-6911	Plastic	50
C-2318	Polyester Film	50
C-2141	Ceramic	50
ASTM:		
D-257	General	26/50/76

Table 2. Major Standards for plate type insulation materials

The open error correction capability built into the 4339B minimizes error caused by the test fixture, allowing reliable measurements.

Conclusion

Agilent's 4339B High-Resistance Meter and 16008B test fixture are carefully engineered and built to overcome the problems traditionally encountered in making accurate insulation resistance measurements. This equipment lets you achieve remarkably better reliability and efficiency when characterizing plate-type insulation materials.

By internet, phone, or fax, get assistance with all your test and measurement needs.

Online Assistance

www.agilent.com/find/assist

Phone or Fax

United States:
(tel) 1 800 452 4844

Canada:
(tel) 1 877 894 4414
(fax) (905) 206 4120

Europe:
(tel) (31 20) 547 2323
(fax) (31 20) 547 2390

Japan:
(tel) (81) 426 56 7832
(fax) (81) 426 56 7840

Latin America:
(tel) (305) 269 7500
(fax) (305) 269 7599

Australia:
(tel) 1 800 629 485
(fax) (61 3) 9210 5947

New Zealand:
(tel) 0 800 738 378
(fax) (64 4) 495 8950

Asia Pacific:
(tel) (852) 3197 7777
(fax) (852) 2506 9284

Product specifications and descriptions in this document subject to change without notice.

Copyright © 1999, 2000 Agilent Technologies
Printed in U.S.A. 10/00
5968-3400E



Agilent Technologies

Innovating the HP Way