

## Application Notes Regarding Jandel Four Point Probe Heads

The work involved in building a Jandel four-point probe head is similar in some ways to horology (watch making) in that it is laborious, meticulous, and time consuming. The founder of Jandel Engineering is, among other things, a trained horologist. Jandel's probe production department consists of 6 individuals, with final assembly conducted by four senior employees, three of whom boast more than 15 years experience. The process involves grinding and polishing of the probe needles to a specific radii, precision machining of various parts, the installation of tiny jeweled bearings as probe guides, and meticulous assembly. Final testing involves the use of calibrated measurement instruments including an optical interferometer, a video inspection system, and an electronic force gauge. All Jandel probe heads meet stringent accuracy requirements for tip radii, tip spacing, tip planarity, and spring loads.

### General Specifications

Jandel Probes are made almost entirely of non-magnetic materials except for the piano wire springs. Most of the probes have an aluminum body, nosepiece, and upper guide. The tips are tungsten carbide and include jewel bearings, i.e. upper and lower synthetic ruby needle guides. There are a few tiny stainless steel screws used. The standard temperature limit for the Cylindrical probe is +120°C. Jandel offers a high-low temperature version of the Cylindrical probe which has a jeweled nosepiece pad in place of the standard acrylic pad. This version can withstand temperatures from LN2 temperature (77K) up to +200°C

### Accuracy

Jandel Probes are built to a high level of mechanical accuracy. Tip spacings are within a 10 micron tolerance and spring loads are set to within +/- 5 grams. Tip radii tolerance is quoted at 10%, however, the most common radii such as 40 and 100 micron are typically within 5%.

### Spacing

Jandel offers probes with close needle spacing (0.5 mm) in several models including the Cylindrical Probe, Six-Way Probe, Four-Pin Probe, and Cartridge with Lead. Probes built with 0.5mm tip spacing are available with spring loads of up to 100 grams only. Tip spacings are available up to 1.591mm. Tip spacing is measured from the center of the contact area. To measure the tip spacing, the needles are pressed onto a sapphire flat and then interference rings are viewed using an optical interferometer. A micron graduated micrometer is used to ensure the distance between the centers of the rings.

### Spring Loads

Jandel uses a custom-made electronic force gauge to set and check the loads for each needle individually. The Cylindrical probe, which is one of several probe body styles that Jandel offers, has a user adjustable pressure which can be adjusted within one of three ranges as follows: 10 to 30 grams, 30 to 60 grams, or 60 to 150 grams of pressure per tip. Spring loads above 150 are available, up to 200 grams, but are fixed without adjustment. The pressure adjustment knob on the top of the Cylindrical probe is made of Teflon. Turning the spring load adjustment knob clockwise increases the load. The stated spring load is achieved at the point where the probe head has been lowered until the acrylic nosepiece pad has touched the material being tested. The Cylindrical probe is the model used on all Jandel probe units. Only the [Cylindrical probe](#) and the [Compact Probe](#) have user adjustable pressure.



Jandel Cylindrical Probe

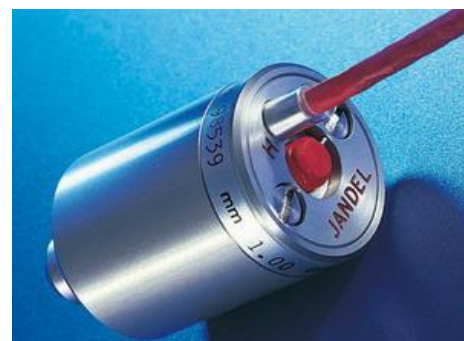

## Spring Loads (continued)

The Cylindrical and similar model Jandel probes can be built with 250 gram loads on probes that have tip spacing of 1mm or greater, however, Jandel warns of accelerated tip wear.

## Tip Material

Jandel Engineering offers two probe tip materials, i.e., tungsten carbide and 50% osmium alloy. Osmium alloy tips are somewhat softer and less durable, and only in a few instances do they provide sufficiently superior contact to justify their usage. Here are some comments from the founder of Jandel Engineering Ltd, John Clark, regarding the usage of osmium alloy tips compared with the much more common and more durable tungsten carbide tips: *"The limit of our knowledge of osmium as an ELEMENT is that it is the most dense, and that it cannot be fabricated. The material we use for probe tips is used for 'pen-balls' - those used on gold pen nibs to give a long writing life. The ones we use are a mixture of platinum group metals including osmium, platinum, rhodium, palladium etc. The specification we had merely stated "not less than 50% osmium alloy". We have had this checked by a laboratory and it was true at that time, some years ago, and this was for a proprietary alloy "Irit 57" made by the Degussa company. From our point of view "osmium" (alloy) tips are a lot softer than TC and inclined to crumble when we shape them. For this reason we are cautious when we accept requests for less than 100 microns x 100g, and really don't like the idea of making 40 microns. I am fairly sure it is more conductive, and may possibly offer less contact resistance in some circumstances. Our output of osmium tipped probes is less than 2% of the total we make and I guess this is on account of their failure to maintain a tip profile for very long. Going back to the early days of 4-point probing, people used to make their own probe heads with 'gramophone needles' (not fibre!). Such needles were often osmium alloy tipped, so are the needle points used in moving iron and moving coil meters. I think the use of osmium alloy here was more against corrosion than anything else. Cynically it is my belief that the use of osmium alloy tips originated from these early attempts and has persisted to the present day."*

## Tip Radii

Radii of 100 microns or less are applied as a whole radius and larger radii are applied to a 150 micron flat. In some instances 500 micron radii can be applied to the whole of the tip, although the needle is only 400 microns diameter so this is not quite a 'full' radius. The needle material is tungsten carbide and therefore very hard, however repeated use will eventually produce 'flats' on the end of the radii. This will not necessarily prevent the probe from working, and erroneous results are the best guide to when a probe head is no longer working at an optimum level. Jandel has never been able to find a probe tip supplier that can provide tips that meet their requirement for radius accuracy. Jandel hand-grinds all of their tips on a precision watchmaker's lathe, and then makes fine adjustments to the tip shapes using diamond files and diamond paste.

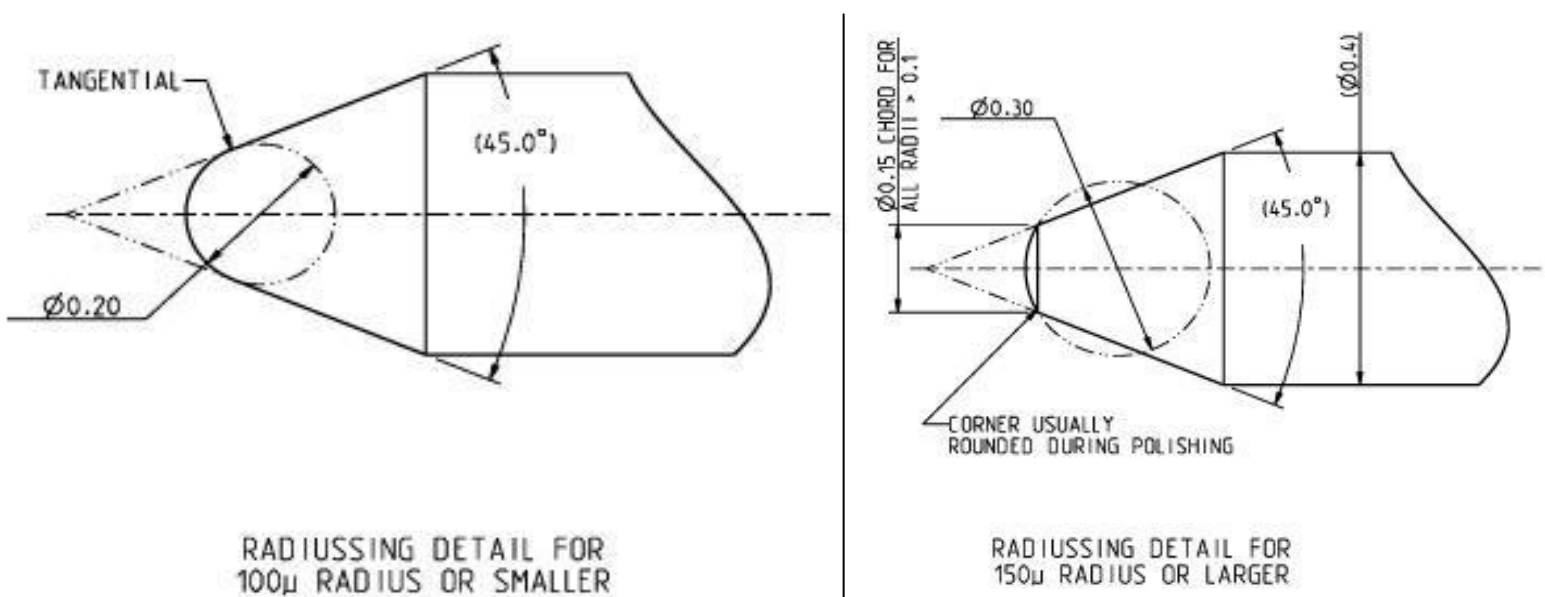

## Planarity

During manufacture, the needles are observed by the maker to visually check planarity using a reflective surface. To the trained eye it is very obvious if the needles progressively rise or fall in relation to the pad. During final inspection a force gauge is set to make an audible tone when the sensor contacts the needle. The tester checks the value on the micrometer gauge for each of the needle contact points and in this way the planarity can be evaluated.

## Retraction

Probe tip retraction distance for the Cylindrical probe is set to 0.5mm. The distance is measured as the distance from full tip extension to the point at which the tip is retracted until the acrylic nosepiece pad touches the material being measured.

## Cable

The standard cable used on Jandel probes is a 0.1mm multi-core for the internal laid up wires. The internal wires are coated in PTFE, and the outer jacket is also PTFE coated. Insulation is at a minimum of least  $10^{13}$  ohms between wires at 500 volts.

## Linear or Square Tip Array

The standard probe tip array is linear, however, a square array version of the Cylindrical probe is available. The Six-Way Probe, Four-Pin Probe, and Cartridge with Lead are also available in the square array. The choice of square tip array does not affect the price. The square array four-point probe has a smaller footprint which allows smaller samples to be measured, and when probing onto wafers it allows the user to measure closer to the edge of a sample before a correction factor is required. The voltage signal for a square array probe is one half of the voltage signal measured when using a linear array probe. The smaller voltage signal must be taken into account when using four point probing electronics and software that are designed to calculate sheet resistance based upon the assumption that a linear array probe is being used. Square array probes are available with tip spacing as close as 0.635, but not 0.5mm.

Jandel Engineering Limited has been manufacturing high quality four point probe heads since 1967.

Jandel four point probe heads are of the highest quality commercially available anywhere in the world.

For further information, contact:

**Bridge Technology**  
**PO Box 9275**  
**Chandler Heights, AZ 85227**  
**Tel: 480-988-2256**  
**Cell: 480-242-6703**  
**Fax: 480-452-0172**  
**Email: [sales@bridgetec.com](mailto:sales@bridgetec.com)**  
**Web: [www.fourpointprobes.com](http://www.fourpointprobes.com)**



**In 2007 Jandel Engineering  
celebrated 40 years in business**

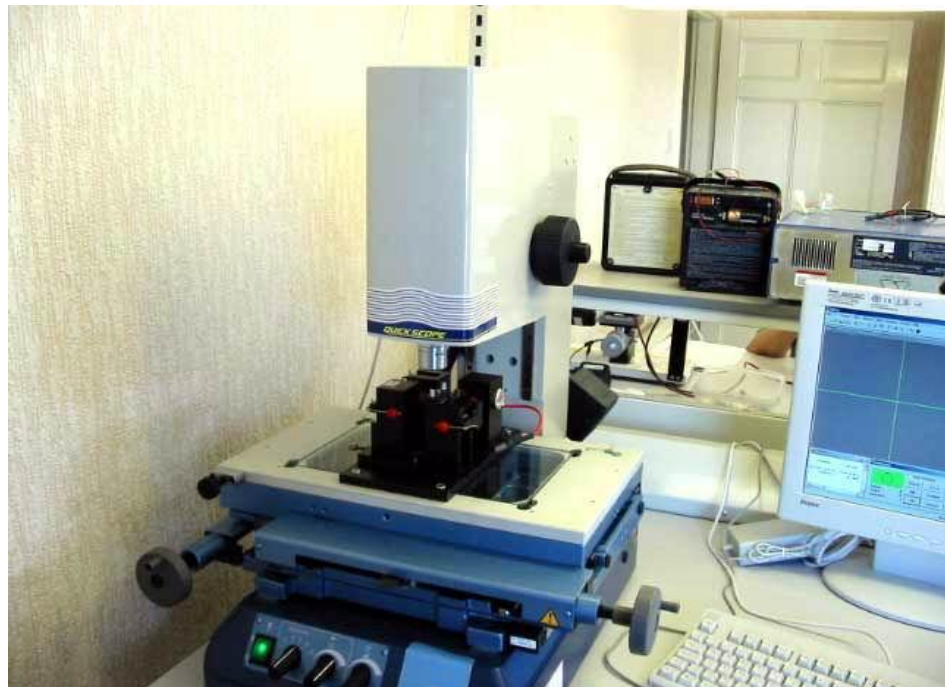

**One of two video inspection systems that Jandel uses**